

THIS DRAWING IS UNPUBLISHED. RELEASED FOR PUBLICATION  
 © COPYRIGHT BY TYCO ELECTRONICS CORPORATION. ALL RIGHTS RESERVED.

LOC	DIST	REVISIONS			
P	LTR	DESCRIPTION	DATE	DWN	APVD
AG	53	0	RELEASED	25JAN06	JDP JGH

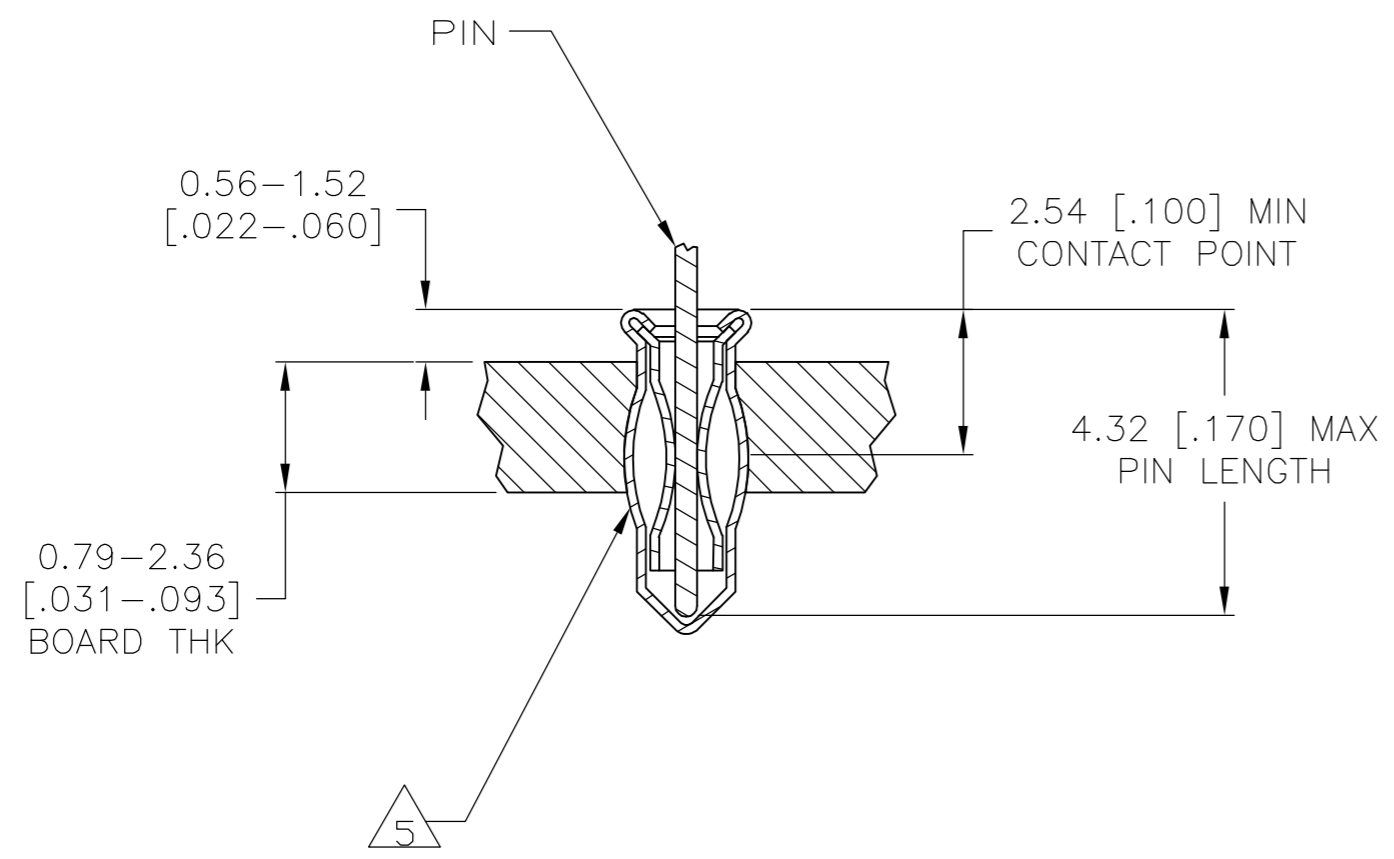
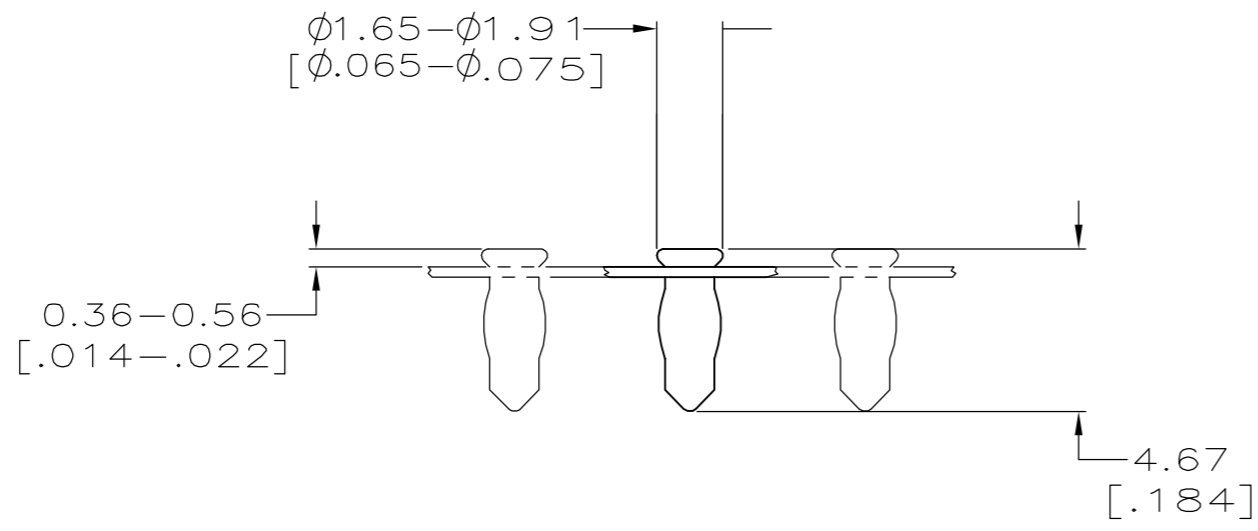
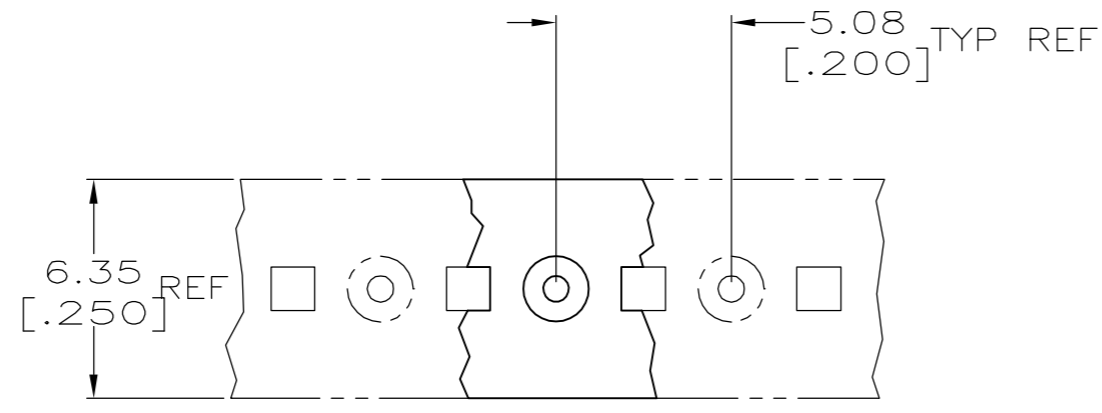

- 1 MATERIAL:  
EYELET - COPPER PER ASTM B 152  
SPRING - BERYLLIUM COPPER PER ASTM B 194
- 2 TIN PLATE PER ASTM B 545, 0.00254 [.000100] MIN THK.
- 3 PACKAGED, 50,000 PER REEL
- 4 TO INSURE 1/2 OZ MIN RETENTION DO NOT EXCEED 0.10 [.004] DIFFERENCE IN PIN DIA WHEN CHANGING TO A SMALLER DIA PIN
- 5 PRODUCT IS OVALIZED FOR RETENTION IN THE P.C. BOARD. THE RECOMMENDED HOLE DIAMETER IS 1.32 [.052] MINIMUM, +0.08 [.003] MAX. PRIOR TO SOLDERING.
- 6 PACKAGED 10,000 PER REEL

2.54-4.32 [.100-.170]	0.36-0.66 [0.014-0.026]	TIN 2	TIN 2	6 1-5645956-1
2.54-4.32 [.100-.170]	0.36-0.66 [0.014-0.026]	TIN 2	TIN 2	3 5645956-1
LENGTH	DIA 4	SPRING	EYELET	PART NO.

THIS DRAWING IS A CONTROLLED DOCUMENT.		DWN	J. POLIGNONE	25JAN06	Tyco Electronics Corporation Harrisburg, PA 17105-3608							
DIMENSIONS: mm [INCHES]		CHK	J. HAVENER	25JAN06								
TOLERANCES UNLESS OTHERWISE SPECIFIED:		APVD	J. HAVENER	25JAN06								
0 PLC ± - 1 PLC ± - 2 PLC ± - 3 PLC ± 0.20[.008] 4 PLC ± - ANGLES ± - FINISH SEE TABLE		PRODUCT SPEC	108-14008			NAME	MINIATURE SPRING SOCKET ASSY					
MATERIAL 1		APPLICATION SPEC	114-26004		SIZE	A2	CAGE CODE	00779	DRAWING NO	C=5645956	RESTRICTED TO	-
		WEIGHT	-		SCALE	1:1		SHEET	1 of 1		REV	0
		CUSTOMER DRAWING										